

2

International Standard



6634

INTERNATIONAL ORGANIZATION FOR STANDARDIZATION • МЕЖДУНАРОДНАЯ ОРГАНИЗАЦИЯ ПО СТАНДАРТИЗАЦИИ • ORGANISATION INTERNATIONALE DE NORMALISATION

Fruits, vegetables and derived products — Determination of arsenic content — Silver diethyldithiocarbamate spectrophotometric method

Fruits, légumes et produits dérivés — Détermination de la teneur en arsenic — Méthode spectrophotométrique au diéthylthiocarbamate d'argent

First edition — 1982-12-01

UDC 634.1/635.6 : 543.42 : 546.19

Ref. No. ISO 6634-1982 (E)

Descriptors : agricultural products, fruits, vegetables, chemical analysis, determination of content, arsenic.

Price based on 5 pages

Foreword

ISO (the International Organization for Standardization) is a worldwide federation of national standards institutes (ISO member bodies). The work of developing International Standards is carried out through ISO technical committees. Every member body interested in a subject for which a technical committee has been set up has the right to be represented on that committee. International organizations, governmental and non-governmental, in liaison with ISO, also take part in the work.

Draft International Standards adopted by the technical committees are circulated to the member bodies for approval before their acceptance as International Standards by the ISO Council.

International Standard ISO 6634 was developed by Technical Committee ISO/TC 34, *Agricultural food products*, and was circulated to the member bodies in June 1981.

It has been approved by the member bodies of the following countries :

Austria	Iran	Portugal
Brazil	Israel	Romania
Canada	Kenya	South Africa, Rep. of
Czechoslovakia	Korea, Dem. P. Rep. of	Spain
Egypt, Arab Rep. of	Korea, Rep. of	Sri Lanka
Ethiopia	Malaysia	Tanzania
France	Netherlands	Thailand
Germany, F.R.	New Zealand	Turkey
Hungary	Philippines	Yugoslavia
India	Poland	

The member body of the following country expressed disapproval of the document on technical grounds :

Australia

Fruits, vegetables and derived products — Determination of arsenic content — Silver diethyldithiocarbamate spectrophotometric method

1 Scope and field of application

This International Standard specifies a method for the determination of the arsenic content of fruits, vegetables and derived products.

2 Reference

ISO 5515, *Fruits, vegetables and derived products — Decomposition of organic matter prior to analysis — Wet method.*

3 Principle

Decomposition of a test portion, reduction of arsenic(V) to arsenic(III) with tin(II) chloride and transformation of the arsenic into arsine by the action of nascent hydrogen. Formation of a red coloured complex by the action of the arsine on silver diethyldithiocarbamate and spectrophotometric measurement at a wavelength of 520 nm.

4 Reagents

All reagents shall be of recognized analytical purity and shall, in particular, be free from arsenic (with the exception of the standard arsenic solution (4.9)). The water used shall be distilled water or water of at least equivalent quality.

4.1 Sulphuric acid, $\rho_{20} = 1,84$ g/ml.

4.2 Nitric acid, $\rho_{20} = 1,38$ g/ml.

4.3 Perchloric acid, $\rho_{20} = 1,67$ g/ml.

4.4 Platinized zinc, prepared as follows.

Place a portion of granulated zinc in a capsule, and pour in a volume of 0,05 g/l platinum chloride solution sufficient to cover the zinc. Leave in contact for 30 min, pour off the liquid, wash with water, leave the platinized zinc to drain on a square

of blotting-paper folded into several layers, and allow to dry. Store in a dry bottle.

The platinized zinc thus prepared shall be submitted to the preliminary test (see 6.1.1).

NOTE — Non-platinized zinc granules may be used if the product is shown to be suitable by the preliminary test.

4.5 Potassium hydroxide, in pellets.

4.6 Tin(II) chloride solution, prepared as follows.

Carry out a cold attack on 20 g of pure granulated tin with 100 ml of concentrated hydrochloric acid ($\rho_{20} = 1,19$ g/ml).

Store in the presence of metallic tin, protected from air, in a bottle provided with a security device (to avoid overpressures caused by the liberation of hydrogen).

4.7 Potassium iodide, 100 g/l solution.

4.8 Sodium hydroxide, standard volumetric solution, $c(\text{NaOH}) = 1$ mol/l.

4.9 Arsenic, standard solution corresponding to 10 mg of arsenic(V) per litre, prepared as follows.

4.9.1 Dissolve, in a 500 ml flask, 264 mg of pure, dry arsenic trioxide in 10 ml of the sodium hydroxide solution (4.8), make up the volume to about 100 ml with water, add 15 ml of 1 mol/l hydrochloric acid solution and two drops of bromine; heat to boiling in order to expel the excess bromine, cool, transfer quantitatively to a 200 ml volumetric flask and make up to the mark with water.

1 ml of this solution contains 1 mg of arsenic.

4.9.2 By means of a pipette, transfer 10 ml of the solution (4.9.1) to a 1 000 ml volumetric flask. Make up to the mark with water.

1 ml of this standard solution contains 10 μg of arsenic(V).

4.10 Silver diethyldithiocarbamate, standard solution, prepared as follows.¹⁾

4.10.1 Dissolve 3,4 g of silver nitrate in 200 ml of water; cool the solution to a temperature close to 10 °C.

4.10.2 Dissolve 4,5 g of sodium diethyldithiocarbamate in 200 ml of water; cool this solution to the same temperature as the silver nitrate solution (4.10.1).

4.10.3 Add slowly, and with constant shaking, the sodium diethyldithiocarbamate solution to the silver nitrate solution; collect the precipitate on a fritted glass crucible of porosity grade P 40, wash with water previously cooled to a temperature close to 10 °C, then dry under reduced pressure at ambient temperature, in the dark.

Dissolve the dried silver diethyldithiocarbamate in cold pyridine. Add cold water to precipitate the product. Filter the precipitate and wash with cold water until all traces of pyridine have been eliminated (this can be verified using a pH indicator paper : the pH of the washings shall not be greater than 6,5). Dry the light yellow crystals of silver diethyldithiocarbamate in a desiccator under reduced pressure.

The crystals shall be kept in a cold, dark place in a glass bottle fitted with a ground glass stopper.

4.10.4 Dissolve 0,4 g of L-ephedrine in about 200 ml of chloroform, add 0,6 g of the silver diethyldithiocarbamate crystals (4.10.3), shake for 15 to 20 min, filter, and make up the volume to 250 ml with chloroform.

This reagent may be stored in a refrigerator in the dark for up to two weeks in a well stoppered bottle.

4.11 Phenolphthalein, 10 g/l ethanolic solution.

5 Apparatus

Ordinary laboratory equipment, and in particular

5.1 Round-bottomed flasks, of capacity 1 000 ml.

5.2 Volumetric flasks, of capacity 50 and 250 ml.

5.3 Beakers, of capacity 50 ml.

5.4 Pipettes, of capacity 1, 2, 5, 10, 20 and 50 ml.

5.5 Burette.

5.6 Apparatus for the determination of arsenic, for example as shown in the figure, comprising :

5.6.1 Conical flask, of capacity 100 ml, fitted with a screw thread joint system for connection to the column 5.6.2.

5.6.2 Column, of height 200 mm and diameter 15 mm, to fit the flask (5.6.1) at its base and fitted with a screw thread joint at the top.

5.6.3 Delivery tube, of internal diameter 4 mm, bent twice, at right angles 80 mm apart, to fit the column (5.6.2) at one end and tapered at the opposite end.

5.6.4 Bubbler, which may consist of a measuring cylinder of capacity 10 ml graduated in 0,1 ml divisions.

5.7 Spectrophotometer, suitable for use in the visible region of the spectrum, for measurements of absorbance at 520 nm, fitted with suitable cells of optical path length 10 mm.

5.8 Analytical balance.

6 Procedure

6.1 Preliminary tests on reagents²⁾

6.1.1 Verification of the reactivity of the zinc and silver diethyldithiocarbamate solution

6.1.1.1 Place, at the bottom of the column (5.6.2) of the apparatus (5.6), a plug of glass wool and add potassium hydroxide pellets (4.5) to a height of 6 to 8 cm. Fit the delivery tube (5.6.3) to the column (5.6.2).

Place the end of the delivery tube (5.6.3) in the bubbler (5.6.4) into which 4 ml of the silver diethyldithiocarbamate solution (4.10) have been placed. Cool the reagent by placing the bubbler in an ice-water bath.

6.1.1.2 Place in the conical flask (5.6.1) 0,5 ml of the standard arsenic solution (4.9) and sufficient water to make the volume up to about 35 ml; add 5 ml of the sulphuric acid (4.1), cool, add 2 drops of the tin(II) chloride solution (4.6), and then 5 ml of the potassium iodide solution (4.7). Leave in contact for 15 min, add 5 g of the platinized zinc (4.4), and plug rapidly by fitting the column (5.6.2) and the delivery tube (5.6.3).

Place the conical flask in a cold water bath and put the whole apparatus in a dark place.

1) This reagent is also available commercially.

2) These tests shall only be carried out when using a new supply of reagents.

6.1.1.3 Allow the reaction to proceed for at least 1 h. Remove the delivery tube (5.6.3). If necessary, adjust the volume in the bubbler to 4 ml with the silver diethyldithiocarbamate solution (4.10). Mix.

By means of the spectrophotometer (5.7), measure the absorbance at 520 nm of the solution in the bubbler, using as the reference solution the silver diethyldithiocarbamate solution (4.10). The absorbance shall be at least 0,12.

6.1.2 Verification of the absence of arsenic in the reagents

6.1.2.1 Prepare the column (5.6.2), the delivery tube (5.6.3) and the bubbler (5.6.4) of the apparatus (5.6) in the same way as for the test specified in 6.1.1.1.

6.1.2.2 Place in the conical flask (5.6.1) 35 ml of water and 5 ml of the sulphuric acid (4.1) and cool; then add 2 drops of the tin(II) chloride solution (4.6), and 5 ml of the potassium iodide solution (4.7). Leave in contact for 15 min, add 5 g of the platinized zinc (4.4), plug rapidly by fitting the column (5.6.2) and the delivery tube (5.6.3) and place the apparatus in a dark place.

Proceed as described in 6.1.1.3.

The absorbance, compared with that of the silver diethyldithiocarbamate solution as reference solution (4.10), shall be less than 0,015.

NOTE — The absence of arsenic in the nitric and perchloric acids is verified by the blank test (6.4).

6.2 Preparation of the test sample

Mix the laboratory sample thoroughly. If necessary, first remove seeds and hard seed-cavity walls and pass the remainder through a mechanical grinder.

Allow frozen or deep-frozen products to thaw beforehand in a closed vessel and add the liquid formed during this process to the product before homogenization.

6.3 Test portion

6.3.1 Liquid products

By means of a pipette, transfer 50 ml of the test sample (6.2) to a 1 000 ml flask (5.1).

If the liquid contains ethanol, expel it by boiling, and allow to cool.

6.3.2 Pasty, solid or dehydrated products

Weigh, to the nearest 0,01 g, a mass of the test sample (6.2) corresponding to 50 to 100 g of fresh product, according to the nature of the sample, and place it in a 1 000 ml flask (5.1).

NOTE — If the sample is rich in organic matter, decomposition will require more time and the mass of the test portion should, therefore, be minimal.

6.4 Blank test

Carry out a blank test following the same procedures as for the determination, but replacing the test portion by 50 ml of water.

NOTE — The blank test is not necessary if the absence of arsenic in the reagents used for decomposition has been verified.

6.5 Decomposition

Add to the contents of the flask 10 ml of the sulphuric acid (4.1) and 20 to 30 ml of the nitric acid (4.2) and, if necessary, a few drops of the perchloric acid (4.3). Proceed as described in ISO 5515.

When decomposition is complete, transfer the solution to a 50 ml volumetric flask (5.2), rinse the original flask with water, and use the rinsings to make up the volume in the volumetric flask to the mark. Mix by shaking.

6.6 Titration of the acidity of the solution

Transfer, by means of a pipette, 2 ml of the solution obtained in 6.5 to a beaker (5.3), dilute with a few millilitres of water, and titrate against the sodium hydroxide solution (4.8) in the presence of two drops of phenolphthalein (4.11).

The concentration, C , of sulphuric acid in the solution obtained in 6.5, expressed in grams per 100 ml, is equal to

$$0,049 \times n \times 50$$

where n is the volume, in millilitres, of sodium hydroxide solution (4.8) used,

or, expressed in millilitres of sulphuric acid ($\rho_{20} = 1,84$ g/ml) per 100 ml of solution

$$C' = \frac{C}{1,84}$$

6.7 Colorimetric determination

6.7.1 Prepare the column (5.6.2), the delivery tube (5.6.3) and the bubbler (5.6.4) of the apparatus (5.6) as indicated in 6.1.1.1.

6.7.2 Place in the conical flask (5.6.1) a volume, V , of the solution obtained in 6.5, corresponding to 5 ml of pure sulphuric acid, calculated from the formula

$$V = \frac{5 \times 100}{C'}$$

If necessary, add water to obtain a volume of about 40 ml. Allow to cool.

Add two drops of the tin(II) chloride solution (4.6) and 5 ml of the potassium iodide solution (4.7). Leave in contact for 15 min. Add 5 g of platinized zinc (4.4) to the contents of the

conical flask (5.6.1). Rapidly stopper the flask by fitting the column (5.6.2) and the delivery tube (5.6.3) and place the apparatus in the dark, with the conical flask placed in a cold water bath.

6.7.3 Allow the reaction to proceed for at least 1 h. Remove the delivery tube. Adjust the volume in the bubbler to 4 ml with diethyldithiocarbamate solution (4.10).

By means of the spectrophotometer (5.7), measure the absorbance at 520 nm of the solution obtained, using the blank test solution (6.4), or the silver diethyldithiocarbamate solution (4.10), as the reference solution, according to the case.

6.8 Calibration curve

Proceed as described in 6.1.1 using 0,5 – 1 – 1,5 and 2 ml of the standard arsenic solution (4.9.2) corresponding to 5 – 10 – 15 and 20 µg of arsenic, and plot a graph having, for example, the mass in micrograms of arsenic as abscissae and the corresponding values of absorbance as ordinates.

7 Expression of results

7.1 Method of calculation and formulae

7.1.1 Liquid products

The arsenic content, expressed in milligrams per litre of product as received, is equal to

$$\frac{m_1}{V}$$

where

m_1 is the mass of arsenic, expressed in micrograms, obtained from the calibration graph and corresponding to the absorbance measured in 6.7.3;

V is the volume, in millilitres, of solution taken for the determination in 6.7.2.

7.1.2 Pasty, solid or dehydrated products

The arsenic content, expressed in milligrams per kilogram of product as received, is equal to

$$\frac{m_1 \times 50}{V \times m_0}$$

where

m_0 is the mass, in grams, of the test portion (6.3.2);

m_1 is the mass of arsenic, expressed in micrograms, obtained from the calibration graph and corresponding to the absorbance measured in 6.7.3;

V is the volume, in millilitres, of solution taken for the determination in 6.7.2.

If it is desired to express the arsenic content in relation to the dry product, take this fact into account in the calculation.

7.2 Repeatability

The difference between the results of two determinations, carried out simultaneously or in rapid succession by the same analyst, on the same sample, shall not exceed 10 % as a relative value.

8 Test report

The test report shall show the method used and the result obtained. It shall also mention the method of expression used and any operating conditions not specified in this International Standard, or regarded as optional, as well as any circumstances that may have influenced the result.

The test report shall include all the information necessary for the complete identification of the sample.

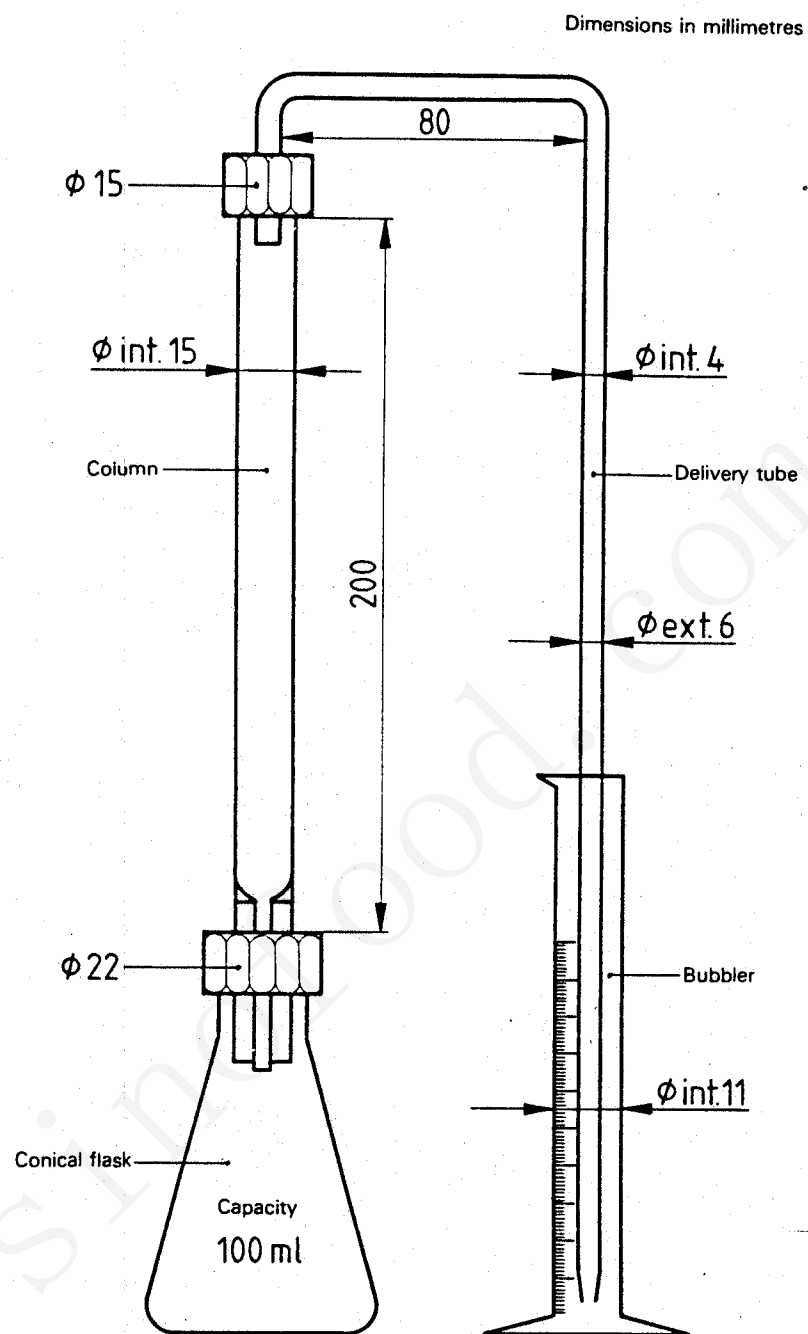

Figure — Example of apparatus for the determination of arsenic (5.6)